



FBF5018 | FBF5022 | FBF5030



Compression head and Homogenizing valve

- The Compression head is manufactured from a single block of high quality stainless steel, of a special type, forged and checked with ultrasounds, with a 5 year guarantee against cracking and defects
- Each valve assembly is housed within an individually inspected special AISI 316 stainless steel block
- Pumping Pistons manufactured with a rear cooling chamber, a double guide to keep a perfect alignment, and a special "Diamond Like Carbon" plating (as a standard)
- Valve group assemblies have replaceable seats and hemispherical valve shutters, ideal for processing a very wide range of products
- Homogenizing valves designed to provide efficient use of energy, with high stability and alignment of the moving parts (impact head) due to the hydrodynamic assembly, which ensures a vibration free homogenization

- Safety valve, in sanitary execution, of spring type with replaceable shutter and seat

Motorization - Structure

- The Pump body is made from a thick walled premium grade high-resistance cast iron, engineered to withstand heavy loads and cancel out vibration
- The crankshaft is made from a special forged steel, machined from a solid piece, "multi-step" heat treatments, super-finishing of the goosenecks and complete nitriding, is checked using ultrasounds. The crankshaft is supported by 5 robust roller bearings (with bronze bearings used only on the crank pins)
- Power transmission with double reduction stage: "V" belts/pulleys, with semi-automatic tensioning system, with two helicoidal gears within the pump body (slow gear coupled directly on the crankshaft).
- Lubricating plant of pressurized type with the level of the oil detected by a proper sensor, cooling of the oil by a tubular heat-

exchanger, an alarm for irregular pressure, an alarm for high temperature, and driven filtering of any possible impurities. For the best thermal balance/dissipating all transmission components are immersed in an oil bath

- 3 phase, 4 pole, AC electric drive motor of leading Company
- The frame is constructed from a square-section carbonated steel pipe coated in a powder painting, and supplied with dismountable stainless steel panels with satin finish

Maintenance kit

- Initial set of spare parts supplied with the machine include the following: full set of gaskets, a set of springs for valves and a complete safety valve set
- Set of tools for ordinary maintenance
- Lubrication oil
- Instruction and maintenance manuals (2 copies + CD ROM)



Technical Features		
FBF5018	kW	18,5
FBF5022	kW	22
FBF5030	kW	30
Pumping pistons	Nr.	3
Water consumption	l/h	90-120
Weight	kg	1.200 - 1.270
Dimensions (LxDxH)	cm	120x155x130

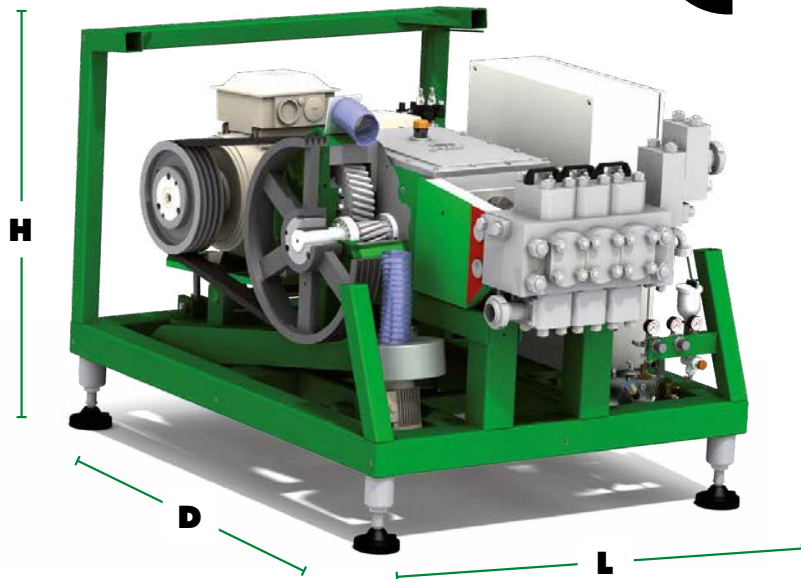

Standard options

- 2nd stage homogenizing valve controlled by a special oil-pneumatic system.
- Digital pressure transducers and analogue gauges with 4-20 mA output
- Fixed Capacity (remote stainless steel panel, with soft-starter)
- Variable Capacity (remote stainless steel panel).
- Aseptic Version with "sterility barriers" traced with steam condensate created by an integrated plant.
- Pulsation dampeners on product inlet and/or outlet connections, for special aseptic version as well.
- Pressure gauge with alarm contacts for the automatic cut-off of the homogenizing pressure, complete with timing device to manage the start/stop of the homogenizing valves
- Automatic homogenization pressure controller.

Functional Features									
Operating pressure	bar	100	130	150	180	200	230	250	300
Capacity	form (l/h)	-	4.700	4.200	3.700	3.200	2.700	2.200	2.200
	to (l/h)	-	6.000	6.000	5.000	4.500	4.000	3.500	3.000

Technical specifications can vary and are subject to change without notice

www.fbftalia.it

FBF ITALIA S.r.l. Via Are, 2 43038 Sala Baganza (Parma) Italy
Phone: + 39 0521 548211 Fax: +39 0521 835179 info@fbftalia.it



Tel: 866-777-6060
Fax: 866-777-6383

Springer Pumps, LLC

Website: www.springerpumps.com
Int'l: +001 267 404 2910

