

MINIFLUX

For pumping out of IBCs



More than just pumps



MINIFLUX

For dry installation / horizontal use on IBC

The MINIFLUX horizontally installed container pump is designed for emptying IBCs via their floor-level outlet. Designed as an alternative to a vertical pump, the MINIFLUX can be used when an IBC is not accessible from the top. It is suitable for applications when gravity draining via the outlet tap is insufficient eg. rapid dispensing, long distance product transfer, or transfer to another container in a higher location. Power can ideally be provided by commutator or compressed air motor.

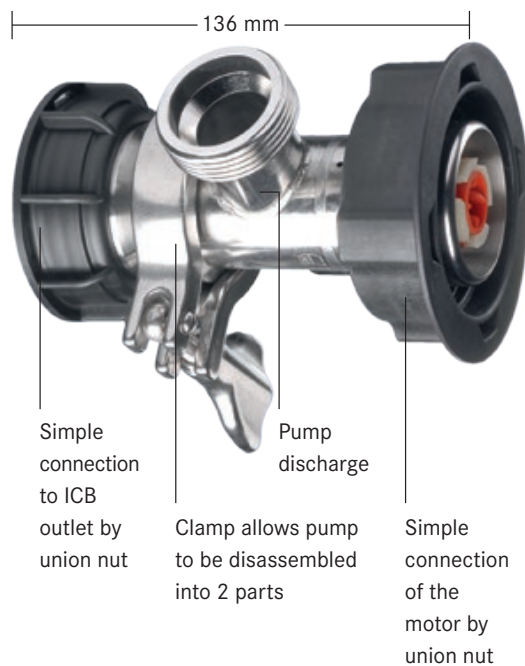

Functional description

The MINIFLUX works on the principle of an axial operating rotary pump. There are a mechanical seal and a radial shaft seal between the product and the driveshaft. This means the shaft only comes into contact with product in the rotor area.

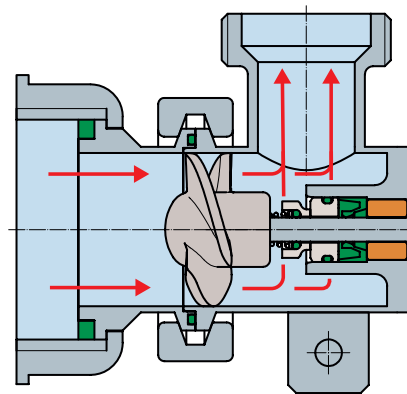

Extremely compact and light.



Also suitable for use in explosion hazard areas of zone 1.**

** corresponding EU Directive 2014/34/EU

Product features

- ▶ For pumping out of IBCs directly from the outlet (with standard S60 x 6 thread)
- ▶ Simple connection of the pump to the outlet by union nut
- ▶ Compact design
- ▶ Can be dismantled into two parts via clamp
- ▶ Low overall weight of 1.2 kg
- ▶ No need to mount pump to top of container
- ▶ Does not require access to the container from above
- ▶ Ideally combined with commutator motor or compressed-air motor

Technical data



Flow rate max.	240 l/min*
Delivery head max.	13 m mwc*
Viscosity max.	1,000 mPas*
Connection to IBC via	Union nut S60 x 6
Pump material	Stainless steel
Weight	1.2 kg
Installation	Dry installation / horizontal

Advantages

- ▶ Can be used where ceilings are low
- ▶ Allows pumping directly from floor-level outlets, even when containers are stacked
- ▶ Significantly higher flow rate and pressure compared to draining by gravity
- ▶ Minimal space requirement
- ▶ Simple disconnection from IBC with union nut
- ▶ Delivery against closed valve (e.g. hand nozzle, flap valve etc.) possible
- ▶ Suitable for use in explosion hazard areas zone 1**



Examples of media

- ▶ Low concentrated acids and lyes
- ▶ Aqueous solutions
- ▶ Solvents
- ▶ Highly flammable liquids
- ▶ Mineral oil products
- ▶ Base materials for the cleaning agent production
- ▶ Diverse raw materials for the cosmetics production



Pumping upward into a mixing container from the IBC outlet.



Fast container filling from the IBC outlet.

* depending on material and motor

** corresponding EU Directive 2014/34/EU



More than just pumps

Today the FLUX name is recognised around the globe as the trademark for top standards in pump technology. Everything started with the invention of the first electric drum pump in 1950. Today the wide range of products includes drum and container pumps, centrifugal immersion pumps, eccentric worm-drive pumps and air-operated diaphragm pumps as well as mixers, flow meters and of course, an extensive range of accessories.

Apart from the outstanding quality of FLUX products, our customers appreciate our staff's expertise and pronounced customer focus.

Put us to the test. We are looking forward to hearing from you.



MINIFLUX 04 16 / 2 - E printed in Germany

FLUX-GERÄTE GMBH

Talweg 12 · D-75433 Maulbronn

Tel +49 (0)7043 101-0 · Fax +49 (0)7043 101-444

info@flux-pumpen.de · www.flux-pumps.com

Tel: 866-777-6060
Fax: 866-777-6383

Springer Pumps, LLC

Website: www.springerpumps.com
Int'l: +001 267 404 2910